

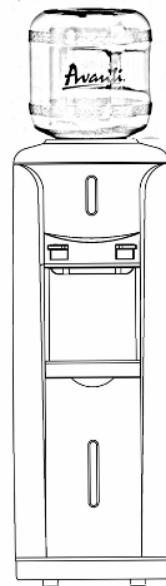

**INSTRUCTION MANUAL  
MANUAL DE INSTRUCCIONES**

**Model Number/Número de Modelo**

**WD361**



**CAUTION:**

**BEFORE USE, PLEASE READ AND FOLLOW ALL SAFETY RULES AND OPERATING INSTRUCTIONS.**

*Avanti has a policy of continuous improvement on its products and reserves the right to change materials and specifications without notice.*

*La sección en español empieza en la página 15*

---

**Avanti Products**  
**P.O. Box 520604 - Miami, Florida 33152**  
**[www.avantiproducs.com](http://www.avantiproducs.com)**

---



## Registration Information

Thank you for purchasing this fine Avanti product. Please fill out this card and return it within 100 days of purchase and receive these important benefits:

✂ **Protect your product:**

We will keep the model number and date of purchase of your new Avanti product on file to help you refer to this information in the event of an insurance claim such as fire or theft.

✂ **Promote better products:**

We value your input. Your responses will help us develop products designed to best meet your future needs.

----- (detach here) -----

### Avanti Registration Card

Name			Model #	Serial #
Address			Date Purchased	Store/Dealer Name
City	State	Zip	Occupation	
<b>As Your Primary Residence, Do You:</b>				
Area Code	Phone Number		<input type="checkbox"/> Own	<input type="checkbox"/> Rent

**Did You Purchase An Additional Warranty:**

Extended     Food Loss     None

**Reason For Choosing This Avanti Product:**

Please indicate the most important factors that influenced your decision to purchase this product.

- Price
- Product Features
- Avanti Reputation
- Product Quality
- Salesperson Recommendation
- Friend/Relative Recommendation
- Warranty
- Other \_\_\_\_\_

**Your Age:**

under 18     18-25     26-30  
 31-35     36-50     over 50

**Marital Status:**

Married     Single

**Is This Product Used In The:**

Home     Business

**How Did You Learn About This Product:**

Advertising     Product Features  
 In Store Demo     Personal Demo

Other \_\_\_\_\_

Comments \_\_\_\_\_

\_\_\_\_\_

\_\_\_\_\_



---

**HELP US HELP YOU...**

**Read this guide carefully.**

It is intended to help you operate and maintain your new water dispenser properly.

Keep it handy to answer your questions. If you don't understand something or you need more help, please call:

**Avanti Customer Service  
800-220-5570**

Keep proof of original purchase date (such as your sales slip) with this guide to establish the warranty period.

**Write down the model and serial numbers.**

You'll find them on a label located on the back side of the unit.

Please write these numbers here:

\_\_\_\_\_  
Date of Purchase

\_\_\_\_\_  
Model Number

\_\_\_\_\_  
Serial Number

Use these numbers in any correspondence or service calls concerning your water dispenser.

If you received a damaged water dispenser, immediately contact the dealer (or builder) that sold you the water dispenser.

Save time and money. Before you call for service, check the Problem Solver Guide. It lists causes of minor operating problems that you can correct yourself.

---

**IF YOU NEED SERVICE**

We're proud of our service and want you to be pleased. If for some reason you are not happy with the service you receive, here are some steps to follow for further help.

FIRST, contact the people who serviced your appliance. Explain why you are not pleased. In most cases, this will solve the problem.

NEXT, if you are still not pleased, write all the details, including your telephone number, and send to:

**Customer Service  
Avanti Products  
10880 NW 30 Street  
Miami, FL 33172**

## PARTS AND FEATURES

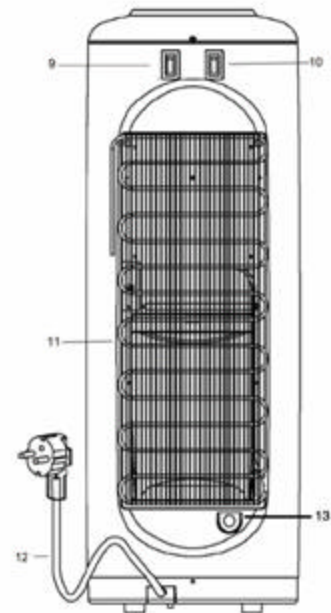
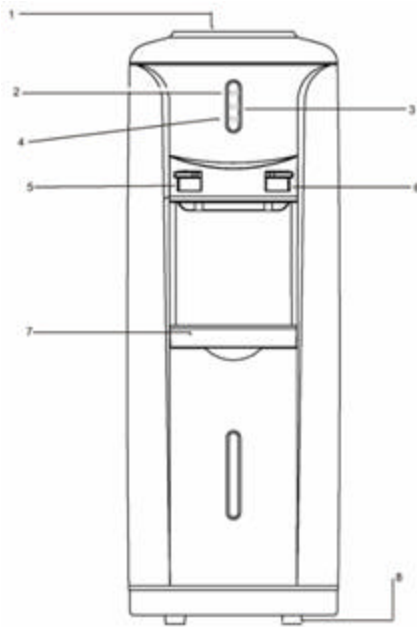



1. WATER INTAKE
2. HOT WATER LIGHT (RED)
3. POWER INDICATOR (YELLOW)
4. COLD INDICATOR LIGHT (GREEN)
5. HOT WATER FAUCET (PINK)
6. COLD WATER FAUCET (BLUE)
7. REMOVABLE DRIPTRAY
8. ADJUSTABLE FOOT
9. COOLING SWITCH
10. HEATING SWITCH
11. CONDENSER COIL
12. POWER SUPPLY CORD
13. WATER DRAIN

## Table of Contents

Registration Information Card	3
Help Us Help You	5
Parts and Features	6
Important Safety Instructions	8
Installation Guidelines	8
Height Adjustment	8
Before Using Your Water dispenser	9
Operating Your Water dispenser	10
Steps To Replace Water Bottles	10
Electrical Connection	10
Cold Water Control	10
Hot Water Control	10
Cup Dispenser (Optional)	11
Care and Maintenance	11
Taking Dispenser Out Of Service	11
Troubleshooting Guide	12
Service For Your Water dispenser	12
Your Avanti Products Warranty	13
Wiring Diagram	14
Instrucciones En Español	15-17

## Important Safety Instructions

 <b>WARNING</b> 	To reduce the risk of burns, fire, electrical shock, or injury when using your appliance, follow these basic precautions:
<ul style="list-style-type: none"><li>? Read all instructions before using the water dispenser.</li><li>? Never clean parts with flammable fluids. The fumes can create a fire hazard or explosion.</li><li>? Do not store or use gasoline or any other flammable vapors and liquids in the vicinity of this or any other water dispenser. The fumes can create a fire hazard or explosion.</li><li>? Do not plug unit into receptacle until you ensure the water tank switches are off.</li></ul> <p style="text-align: center;">-Save these instructions-</p>	

### INSTALLATION GUIDELINES:

- ? Remove the exterior and interior packing.
- ? Place your appliance on a floor that is strong enough to support the dispenser when it is fully loaded. If it does not sit level on the floor, adjust the front right foot to level the unit well to the floor. Note: Only the front right foot is adjustable.
- ? Locate the appliance away from direct sunlight and sources of heat (stove, heater, radiator, etc.). Direct sunlight may affect the acrylic coating and heat sources may increase electrical consumption. Extreme cold ambient temperatures may also cause the appliance not to perform properly.
- ? Allow 2 inches of space between the water dispenser and the wall, which allows for proper air circulation to cool the compressor.
- ? Plug the appliance into an exclusive properly installed-grounded wall outlet. Do not cut or remove the third (ground) prong from the power cord under any circumstances. Any questions concerning power and/or grounding should be directed toward a certified electrician or an authorized Avanti Products service center.
- ? This water dispenser is not recommended for outdoor use.
- ? Do not locate the dispenser in area where the temperature may fall below freezing (32° F).
- ? Keep area around dispenser free of dust and dirt.
- ? Keep the reserve supply of water bottles away from excessive heat and light.
- ? Never unplug the water cooler, except for maintenance.

### Height Adjustment

- ≠ Unit is provided with four feet extensions, if you wish to make the unit taller, just attach all four parts to the bottom feet by placing them on existing feet and pushing firmly to ensure a tight fit. Unit will be slightly taller. The adjustable foot can still be used for leveling after the extension part is inserted.



## OPERATION INSTRUCTIONS:

### Before Using Your Water Dispenser

- ? Check to be sure the following parts are included:
  - ✍ Instruction manual
  - ✍ 4 extra cup dispenser cabinet plugs
  - ✍ Accessories order form.
  - ✍ 4 height adjustment foot extensions
- ? Before connecting the appliance to the power source, let it stand upright for approximately 2 hours. This will reduce the possibility of a malfunction in the cooling system from handling during transportation.
  - ? The water dispenser is pre-cleaned at the factory but the reservoir and water lines must be flushed with fresh water before use as follows:
    - ? Keep the unit unplugged.
    - ? Fill water tank with tap water full to capacity (more than 3/4 of a gallon). Wait for 5 minutes until water settles.
    - ? Press the hot water faucet until water comes out, then stop.
    - ? Plug the dispenser into the electrical outlet. Both heating and cooling indicator lights on front will light up at first. We are ready to complete the first cycle. In order to do that, wait for the hot water indicator light to go off first (approximately 10 minutes), then wait for the cold water indicator light to go off (another 40 minutes, approximately).
    - ? Unplug the dispenser from the electrical outlet. Proceed to drain the water from the faucets one at a time until no more water remains.  
(Note: To facilitate this operation, use a large container).
    - ? Then, drain any water left in the tanks by opening the drain plug located on the back, until it drains completely.
    - ? Proceed to close the drain cap.
    - ? Place the 5-gallon bottle of water on the water intake, allow water to stand for approximately one minute.
    - ? Open water faucets to insure water flows from both faucets.
    - ? Plug dispenser into the electrical outlet.
    - ? Now you are ready to use your water dispenser.

**NOTE:** Your water dispenser has been cleaned and sanitized before leaving the factory, but in case a taste problem develops, place two tablespoons of baking soda and add tap water. Fill water tank again and repeat basic operations previously outlined, except turn the switch marked **HOT** "OFF" to avoid leaving residues in hot water tank.

### **ATTENTION:**

If you do not plan to use the water heating function for more than three days, we recommend that you turn the **HOT** switch to the "OFF" position.

### **ATTENTION:**

If you do not plan to use the water heating function for more than three days, we recommend that you turn the **HOT** switch to the "OFF" position.



**IMPROPER USE OF THE GROUNDED PLUG CAN RESULT IN THE RISK OF ELECTRICAL SHOCK. IF THE POWER CORD IS DAMAGED, HAVE IT REPLACED BY AN AUTHORIZED AVANTI PRODUCTS SERVICE CENTER.**

## OPERATING YOUR WATER DISPENSER

### **✍ Steps to replace water bottles**

- ? Use a clean cloth to wipe off neck of bottle.
- ? Remove cap.
- ? Carefully lift bottle (approx. 40 lbs.) using your legs and not your back. Do not place hands on opening of bottle while placing in reservoir.
- ? Insert the water bottle on the water intake over reservoir opening so it settles properly on it.
- ? Wipe off any water which may have splashed on dispenser top.
- ? When a new bottle is installed you must open the hot water faucet and remove no less than 4 full cups of water to insure the water flows properly and the water reservoir is at the proper level.

### **✍ Electrical Connection**

This appliance should be properly grounded for your safety. The power cord of this appliance is equipped with a three-prong plug which mates with standard three prong wall outlets to minimize the possibility of electrical shock.

Plug the appliance into an exclusive properly installed-grounded wall outlet. Do not under any circumstances cut or remove the third (ground) prong from the power cord. Any questions concerning power and or grounding should be directed toward a certified electrician or an authorized Avanti Products service center.

This appliance requires a standard 115/120-volt, 60Hz electrical outlet with three-prong ground.

The cord should be secured behind the appliance and not left exposed or dangling to prevent accidental injury.

Do not use an adapter plug with this appliance.

Do not use an extension cord with this appliance. If the power cord is too short, have a qualified electrician or service technician install an outlet near the appliance.

### **✍ Cold Water Control**

Turn the cooling switch on. The green indicator will be lit on and the process begins. When the water reaches the right temperature the green light goes off automatically.

### **✍ Hot Water Control**

Turn the heating switch on, the red indicator will be lit on and the heating process starts. When the water reaches the right temperature the red light goes off automatically. When the temperature goes down to approx. 80° C (176° F), the red indicator will glow again and another heating process starts.

**NOTE:**  
**THE HOT WATER FAUCET HAS A CHILD-SAFETY GUARD ATTACHMENT.**

To dispense hot water:

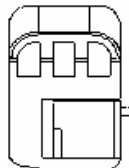

- ? Slide red safety button to the left and hold while pressing downward on hot water faucet to dispense hot water.
- ? Safety button will return to its original position when faucet is released.

### **Cup Dispenser (Optional)**

A cup dispenser may be installed by using the mounting holes (covered with plastic caps) located near the top of the right side panel of the cooler. The cup dispenser comes equipped with a mounting bracket and screws and may be ordered by completing the enclosed order form provided with your instruction manual.

## **CARE AND MAINTENANCE**

- ? Wash the inside of the reservoir with a warm water and baking soda solution. The solution should be about 2 tablespoons of baking soda to a quart of water.
- ? The drip tray and water faucets should be cleaned with mild detergent and warm water.
- ? At regular intervals or once a month inspect the coils located across the back of the dispenser. Vacuum accumulation of dust or clean it with a hard brush.

## **TAKING DISPENSER OUT OF SERVICE**

- ? If the water dispenser will not be used for a long period of time, unplug the power cord from the wall outlet.
- ? Drain the water through the faucets.
- ? Turn the switch marked hot to the "OFF" position.
- ? Drain the water from the tank by removing the plug from the back of the dispenser.

**WARNING—THE WATER COMING OUT OF THE BACK SIDE MARKED "HOT" MAY BE SCOLDING.**

- ✍ Unit should not be transported on the sides. Place it upright if possible and cover it with a blanket.

### PROBLEMS WITH YOUR WATER DISPENSER

You can solve many common water dispenser problems easily, saving you the cost of a possible service call. Try the suggestions outlined below to see if you can solve the problem before calling the service.

#### TROUBLESHOOTING GUIDE

PROBLEM	POSSIBLE CAUSE
Water dispenser does not operate.	Not plugged in. The circuit breaker tripped or a blown fuse.
Water cooler is not cold enough.	Check to be sure the cold switch on the back is ON. The water dispenser does not have the correct clearances.
Water dispenser hot water is not hot enough.	Check to be sure the hot switch on the back is ON.
Compressor turns on and off frequently.	The room temperature is hotter than normal. The temperature control is not set correctly. The water dispenser does not have the correct clearances.
Vibrations.	Check to assure that the water dispenser is level.
The water dispenser seems to make too much noise.	The rattling noise may come from the flow of the refrigerant, which is normal. As each cycle ends, you may hear gurgling sounds caused by the flow of refrigerant in your water dispenser. Contraction and expansion of the inside walls may cause popping and crackling noises. The water dispenser is not level.
Bottle feels warm.	The water system is overfilled. Dispense Cold water until air is released into the bottle.
Water bottle is hot.	Water is boiling in the hot tank and bubbling up into the bottle. Press the hot dispenser button until water flows to remove air from the hot tank.

#### SERVICE FOR YOUR WATER DISPENSER

We are proud of our customer service organization and the network of professional service technicians that provide service on your Avanti appliances. With the purchase of your Avanti appliance, you can have the confidence that if you ever need additional information or assistance, the Avanti Products Customer Service team will be here for you. Just call us toll-free.

#### AVANTI PRODUCTS CUSTOMER SERVICES

Product Information 800-323-5029	Whatever your questions are about our products, help is available.
Part Orders 800-220-5570	You may order parts and accessories that will be delivered directly to your home. You may order these items by personal check, money order, Master Card, or Visa.
In-Home Repair Service 800-220-5570	An Avanti Products authorized service center will provide expert repair service, scheduled at a time that is convenient for you. Our trained servicers know your appliance inside and out.

<b>YOUR Avanti Products WARRANTY</b>	<b>Staple your sales receipt here. Proof of original purchase date is needed to obtain service under warranty.</b>
--------------------------------------	--

**WHAT IS COVERED**

**LIMITED ONE-YEAR WARRANTY**

For one year from the date of purchase by the original owner, Avanti Products will, at its option, repair or replace any part of the appliance which proves to be defective in material or workmanship under normal use. During this period Avanti Products will provide all parts and labor necessary to correct such defects free of charge, so long as the appliance has been installed and operated in accordance with the written instructions in this manual. In rental or commercial use, the warranty period is 90 days.

**LIMITED SECOND THROUGH FIFTH YEAR WARRANTY**

For the second through the fifth year from date of original purchase, Avanti Products will provide a replacement compressor free of charge due to a failure. You are responsible for the service labor and freight charges. In rental or commercial use, the limited compressor warranty is one year and nine months. Cost to move the appliance to the servicers' shop and back to the user's home, as may be required, are the user's responsibility.

---

**WHAT IS NOT COVERED**

- ? Incidental or consequential damages.
- ? Parts and labor costs for the following will not be considered as warranty:
- ? Inner door panels, door shelves, door rails, and/or door supports.
- ? Light bulbs and/or plastic housing.
- ? Plastic cabinet liners.
- ? Punctured evaporator that voids the warranty on the complete sealed system.
- ? Replacement of house fuses or resetting circuit breakers.
- ? Repairs performed by unauthorized servicers.
- ? Service calls that do not involve defects in material or workmanship such as customer education, door reversal, or proper installation.
- ? Service calls that are related to external problems, such as abuse, misuse, inadequate electrical power, accidents, fire, floods, or acts of God.
- ? Failure of the product if it is used for other than its intended purpose.
- ? This warranty does not apply outside the continental U.S.A.

# WIRING DIAGRAM

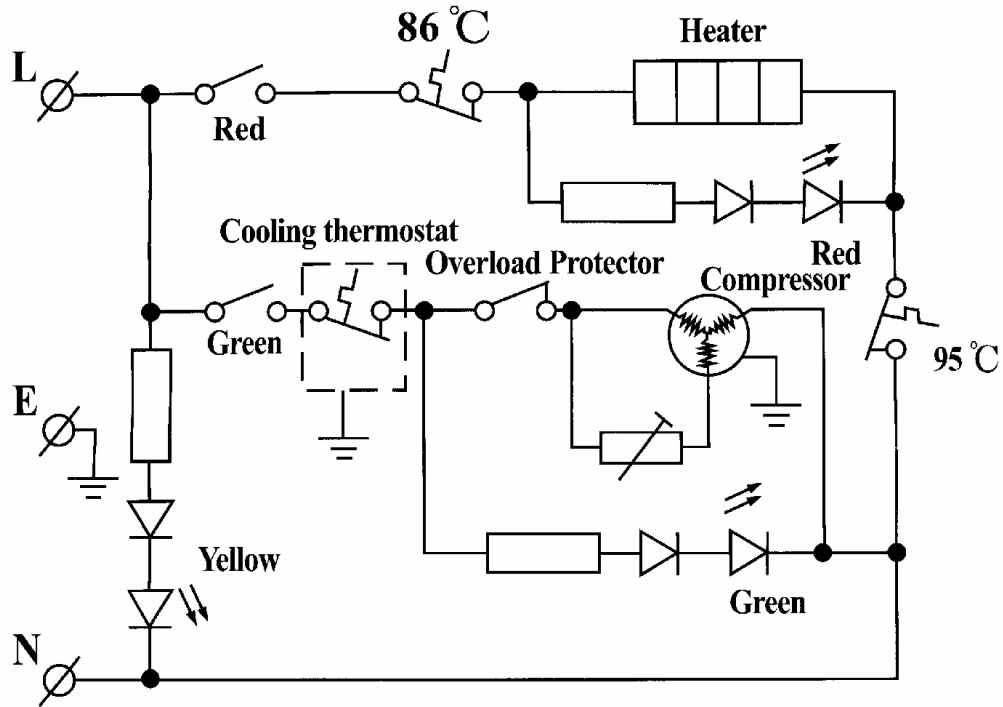

**AVISO:  
ESTE GRIFO DE AGUA CALIENTE TIENE UN ADAPTADOR DE SEGURIDAD PARA NIÑOS.**

PARA OBTENER AGUA CALIENTE:

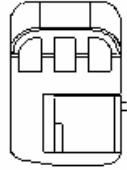

- ? MUEVA HACIA LA IZQUIERDA Y NO SUELTE EL BOTON DE SEGURIDAD.
- ? MANTENGA AGARRADO ESE BOTON DE SEGURIDAD MIENTRAS QUE EMPUJE EL GRIFO HACIA ABAJO PARA DISPENSAR EL AGUA CALIENTE
- ? CUANDO SUELTE EL GRIFO ASEGURESE DE RETORNARLO A LA POSICION ORIGINAL

### **PASOS RECOMENDADOS PARA CAMBIAR EL BOTELLON**

- ✍ QUITA EL BOTELLON VACIO.
- ✍ LIMPIA EL CUELLO DEL BOTELLON NUEVO CON UN TRAPO LIMPIO.
- ✍ LEVANTA EL BOTELLON HACIENDO FUERZA CON LAS PIERNAS Y NO LA ESPALDA.
- ✍ TOMA EL BOTELLON POR LOS LADOS Y DIRIJA EL CUELLO DEL MISMO HACIA LA APERTURA DEL TANQUE.
- ✍ VOLTEA EL BOTELLON COMO SI FUERA A SOLTAR AGUA E INSERTE EL CUELLO DEL BOTELLON EN LA APERTURA DEL TANQUE HASTA QUE SE COLOQUE EN LA POSICION CORRECTA.

DIRECCIONES BASICAS DE OPERACION:

- ✍ COLOQUE EL ENFRIADOR DE PIE POR UN PERIODO DE 2 HORAS ANTES DE ENCHUFAR LA UNIDAD A LA PARED.
- ✍ COLOQUE EL ENFRIADOR EN UN AREA BIEN VENTILADA Y DEJE UN ESPACIO DE UN POCO MAS DE 2 PULGADAS ENTRE LA UNIDAD Y LA PARED.
- ✍ ESCOJA UN LUGAR CON PISO NIVELADO.
- ✍ NO COLOQUE EL ENFRIADOR DONDE LA TEMPERATURA AMBIENTAL PUEDA BAJAR DE 32°F (0°C).

### **ANTES DE ENCHUFARLO**

AUNQUE ENFRIADOR SALE LIMPIO DE LA FABRICA, DEBE LIMPIAR Y ESTERILIZAR LOS CONDUCTOS DEL TANQUE Y LOS GRIFOS DE ACUERDO A LOS SIGUIENTES PASOS:

- ✍ LLENE EL TANQUE DE AGUA (HASTA EL TOPE) CON AGUA DE LA PILA.
- ✍ DEJE NIVELAR EL AGUA POR 5 MINUTOS.
- ✍ ABRA LA LLAVE DE AGUA CALIENTE HASTA QUE SALGA AGUA Y CIERRELA INMEDIATAMENTE.
- ✍ ENCHUFE LA UNIDAD A LA PARED. ENCRENDA LOS DOS INTERRUPTORES SITUADOS EN LA PARTE TRASERA. LOS DOS INDICADORES DE LUZ SE ALUMBRARAN. ESPERE HASTA QUE EL INDICADOR DE AGUA CALIENTE SE APAGUE (APROX. 10 MINUTOS).
- ✍ ENTONCES ESPERE HASTA QUE EL INDICADOR DE AGUA FRIA SE APAGUE (APROX. 5 MINUTOS).
- ✍ DESCONECTE LA UNIDAD DE LA PARED.
- ✍ EMPIEZE A DRENAR LAS LLAVES UNA A LA VEZ HASTA QUE SALGA EL ULTIMO CHORRO DE AGUA.
- ✍ EN LA PARTE TRASERA DE LA UNIDAD ENCONTRARA UNA TAPA PLASTICA. GIRE HACIA LA IZQUIERDA LA TAPA HASTA QUE SALGA EL ULTIMO CHORRO.
- ✍ CUANDO NO SALGA MAS AGUA DE LA APERTURA, CIERRE LA TAPA PLASTICA.
- ✍ TOMA EL BOTELLON DE AGUA Y SIGA LAS INSTRUCCIONES PARA CAMBIAR EL

BOTELLON.

- ✎ ENCHUFE LA UNIDAD. AHORA SU ENFRIADOR ESTA LISTO PARA SU USO.

### **COMO AUMENTAR LA ALTURA**

CON SU UNIDAD ESTAN INCLUIDAS 4 EXTENSIONES PARA AUMENTAR LA ALTURA DE SU ENFRIADOR.

COLOQUE LAS EXTENSIONES SOBRE LAS PATA NORMALES QUE VIENEN CON LA UNIDAD. ASEGURESE QUE ESTAN FIJAS.

LA UNICA PATA NIVELADORA TRABAJARA CON LA EXTENSION PROVEIDA

### **CONTROLES DE OPERACION**

- ✎ CONTROL DE AGUA FRIA:

ABRA LA LLAVE DE AGUA FRIA (10). EL INDICADOR DE LUZ VERDE SE ENCENDERA Y EL PROCESO DE ENFRIAMIENTO COMENZARA. CUANDO LA TEMPERATURA ALCANCE APROXIMADAMENTE 5-7°C LA LUZ VERDE SE APAGARA AUTOMATICAMENTE.

- ✎ CONTROL DE AGUA CALIENTE:

ABRA LA LLAVE DE AGUA CALIENTE (11). EL INDICADOR DE LUZ ROJA SE ENCENDERA Y EL PROCESO DE CALENTAMIENTO DEL AGUA COMENZARA.

CUANDO LA TEMPERATURA ALCANCE APROXIMADAMENTE 80°C LA LUZ ROJA SE APAGARA AUTOMATICAMENTE Y OTRO CICLO DE CALENTAMIENTO EMPEZARA.

### **MANTENIMIENTO**

- ✎ A INTERVALOS REGULARES (UNA VEZ AL MES), INSPECCIONE EL CONDENSADOR O REJILLA DE ALAMBRE LOCALIZADA EN LA PARTE TRASERA DE LA UNIDAD.
- ✎ ANTES DE EFECTUAR LA LIMPIEZA, DESENCHUFE EL ENFRIADOR. USE UNA ASPIRADORA O UN CEPILLO DURO PARA QUITAR EL POLVO.
- ✎ PARA LIMPIAR LAS PARTES DE PLASTICO SE REQUIERE JABON LIQUIDO Y AGUA TIBIA. NO USE LIMPIADORES ABRASIVOS EN LA SUPERFICIE SUPERIOR NI EN LA BANDEJA DE ESCURRIMIENTO.

#### **SI NO VA A USAR EL ENFRIADOR POR UN TIEMPO PROLONGADO**

- ✎ DESENCHUFE LA UNIDAD.
- ✎ QUITE EL BOTELLON DE AGUA.
- ✎ COLOQUE LOS INTERRUPTORES MARCADOS CALIENTE Y FRIO (EN LA PARTE TRASERA) EN LA POSICION "OFF".
- ✎ DRENE EL AGUA ABRIENDO LAS LLAVES.
- ✎ DRENE LA APERTURA EN LA PARTE TRASERA QUITANDO EL TAPON.
- ✎ EL ENFRIADOR DEBE TRANSPORTARSE PARADO Y CUBIERTO CON UNA FRAZADA PARA EVITAR QUE SE RAYE.

### **CENTRO DE SERVICIOS**

LA MAYORIA DE LOS PROBLEMAS SE RESUELVEN CON UNA SIMPLE LLAMADA TELEFONICA A NUESTRO NUMERO SIN CARGO.

**1-800-220-5570**

ANTES DE DEVOLVER EL PRODUCTO O PARA OBTENER LA DIRECCION Y NUMERO DE TELEFONO DEL CENTRO DE SERVICIO MAS CERCANO LLAME AL SIGUIENTE NUMERO.

**1-800-220-5570**



**POSIBLES PROBLEMAS****CAUSA**

DERRAME DE AGUA POR FUERA DEL ENFRIADOR	LA BOTELLA ESTA PERFORADA – REEMPLACELA
EL AGUA NO ESTA SUFICIENTEMENTE FRIA.	SU TEMPERATURA DEBERIA SER DE 5? A 7? C CON UNA TEMPERATURA AMBIENTE DE 20? C. SI NO ES ASI, LLAME AL CENTRO DE SERVICIO, EL TERMOSTATO PODRIA ESTAR DEFECTUOSO.
EL AGUA NO ESTA SUFICIENTE CALIENTE	SU TEMPERATURA DEBERIA SER DE 80? A 90? C CON UNA TEMPERATURA AMBIENTE DE 20? C. SI NO ES ASI, LLAME AL CENTRO DE SERVICIO, EL TERMOSTATO PODRIA ESTAR DEFECTUOSO.
EL ENFRIADOR NO ENFRIA O CALIENTA EL AGUA	VERIFIQUE LOS CIRCUITOS, FUSIBLES O DISYUNTORES.

PRINTED IN CHINA